

# DF(g) series

## 62 DC miniature displacement transducers

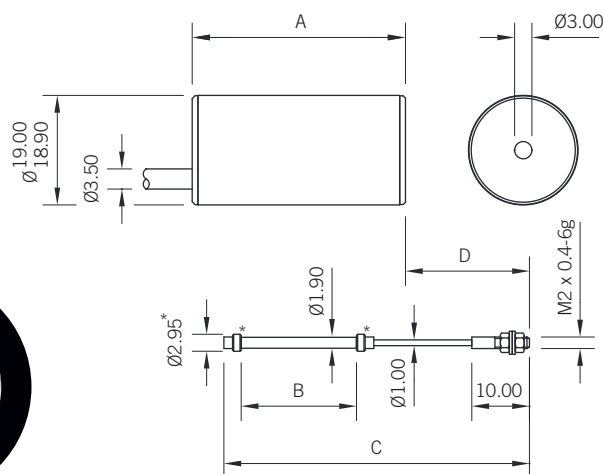
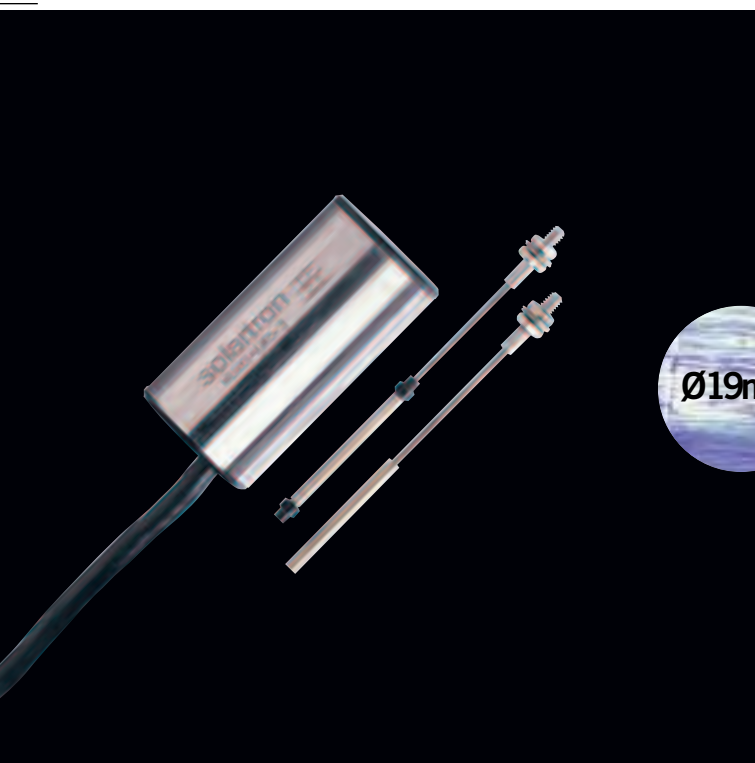

\*Delrin bearings fitted to DFg Series only

Type	'A' Body Length	'B' Core Length	'C' Core + Carrier	'D' At Null
DF1.0/DF2.5	37.00	20.00	50.00	21.50
DFg1/DFg2.5	37.00	20.00	53.00	21.50
DF5	43.00	24.30	54.30	20.50
DFg5	43.00	24.30	57.30	20.50

- > Measurement range to 10mm
- > High output
- > Two types
- > Infinite resolution
- > Excellent repeatability

The DF dc miniature displacement transducer has a friction-free core and the DFg has a free guided core incorporating Delrin bearings. All types incorporate a linear variable differential transformer (LVDT) as the measuring source together with oscillator, demodulator and filter providing a self-contained unit accepting a DC input and providing a DC output relative to armature position.

With high linearity and low mass of moving parts, these are ideally suited to applications in civil, mechanical, chemical and production engineering. Also, when mounted in a suitable load-sensitive member such as a proof ring or diaphragm, they can provide load or pressure measurement.

Product type	DC miniature		
Free	DF1	DF2.5	DF5
Guided	DFg1	DFg2.5	DFg5
Measurement			
Measurement Range (mm)	<b>±1</b>	<b>±2.5</b>	<b>±5</b>
Linearity <sup>(1)</sup>	0.3%		
Temperature Coefficient % FS/°C Zero Sensitivity	<0.02	<0.01	
	<0.025		
Mechanical			
Material	400 stainless steel		
Standard cable length (m)	3		
Length of carrier (protruding at 0 position)	21.5	20.5	
Transducer weight (g)	26	30	
Mass of moving components (g)	1	1.2	
Environmental			
Storage Temperature (°C)	-10 to +80		
Operating Temperature (°C)	-5 to +70		
IP rating	IP65		
Electrical Interface			
Energising Voltage (VDC)	10 to 24		
Energising Current at 10 VDC (mA)	10	13	
Frequency response (-3dB Hz)	50		
Sensitivity at 10 VDC ±10% (mV/V/mm)	75	54	

1 Specification of a transducer at 10VDC and a calibration load of 20kΩ