

orbit3

Digital Measurement System

The Orbit® 3 Digital Measurement System, in conjunction with wide range of transducers, including both contact and non-contact linear measuring transducers (gauging probes), specialist transducers and third party transducer interfaces, provides a limitless set of measuring system solutions, with numerous different interfaces to computers and PLC's, making Orbit® 3 completely flexible.

Orbit® 3 – The Total Measurement System

FEATURES

- **Excellent metrology performance**, high **accuracy**, high resolution and excellent **repeatability**
- Excellent lifetime value – low maintenance costs due to the high reliability of mechanics and electronics
- Wide range of compatible transducers
- **Fast reading rates with high data integrity**
- Network up to 150 different transducers with one interface
- Communicate with any computer or PLC
- Range of Software drivers and tools for easy set up

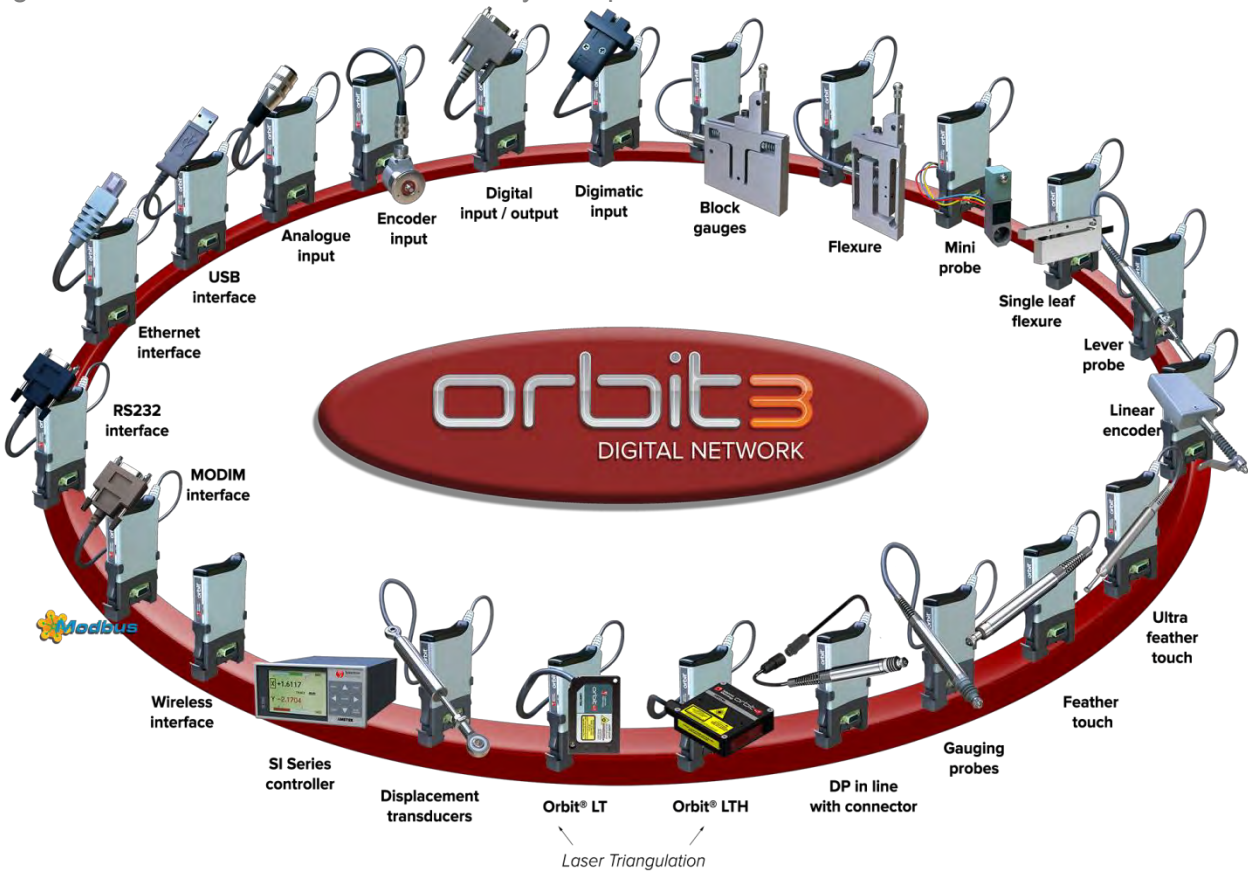



Digital Measurement System

Orbit® 3 is the latest high performance offering from Metrology. Originally developed to provide a simple means of connecting Linear Measuring Transducers into networks by eliminating the need to use analogue transducers and amplifiers which required individual channel set up and ongoing maintenance. Calibrating the transducer and electronics together makes the system very linear across it's full measurement range, thus removing the need for expensive minimum and maximum gauging masters.

The Orbit® system has been continually developed since its introduction in 1998, using in-service data and customer feedback to produce a modern fast digital measurement system that works with a wide range of Solartron and third party sensors. Orbit® 3 provides solutions for many measurement applications, including temperature, load cells, pressure sensors, linear displacement, structural monitoring, gauging and many more.

Orbit® 3 Building Blocks

The system comprised of measurement modules with and without attached transducers, controllers that provide the link between a PC or PLC and the network, software drivers and applications for ease of data capture, specialist cables for high speed data with enhanced integrity, and various specialist power supply modules. All the Orbit® products are fully EMC compliant. The range is further enhanced by digital readouts and the Orbit® ACS products, both of which are ideal for small systems.

Orbit® 3 Module and TCON



Orbit® 3 Modules on DIN rail

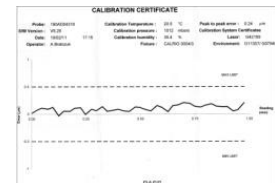

Calibration traceable to UK National Standard



Status indicators on modules

The network is based on DIN Rail mounted modules which employ the unique TCON connection system to allow easy expansion or replacement of measuring modules. TCONs can be left permanently in place and modules/transducers swapped. Status indication lamps on each module show the health of the module.



Orbit® 3 Digital Measurement System: Applications

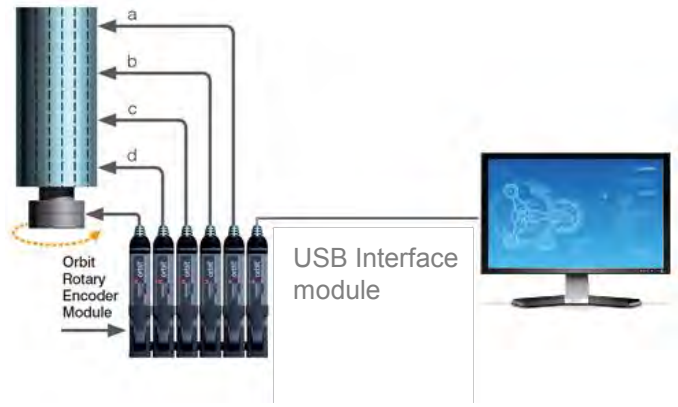

Synchronised high-speed profiling of a rotating cylinder

Check the diameter, weight, and temperature of a piston, all with one connection to PLC

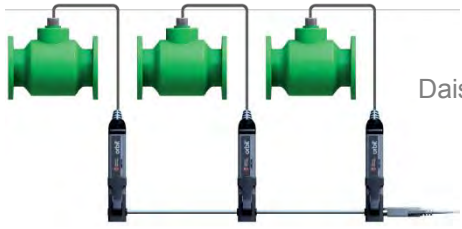
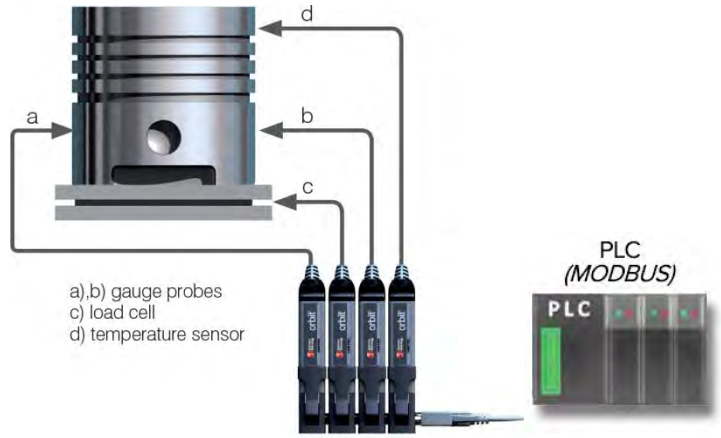

Daisy chained pressure sensors

Network Displacement Transducers to monitor change in a structure

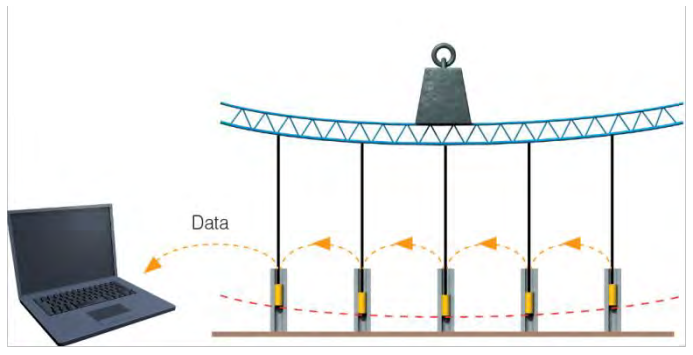



Orbit® 3 Digital Measurement System: Applications

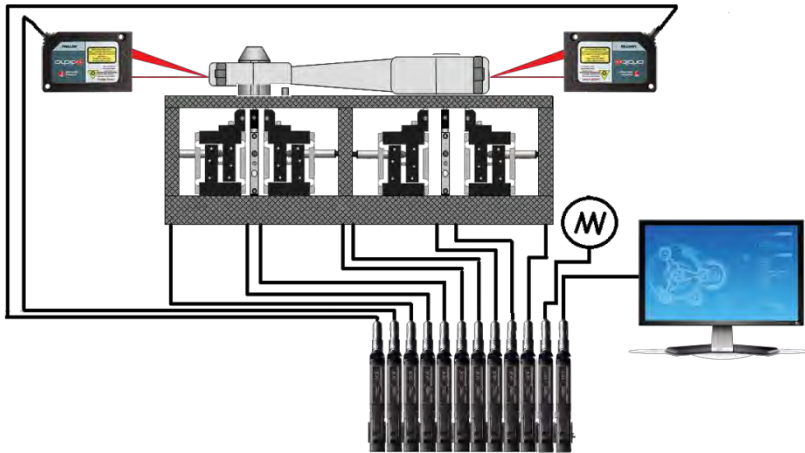

Solartron Flexure Contact Transducers and Non Contact Laser Triangulation Transducers. Connected to PC via USB Controller.

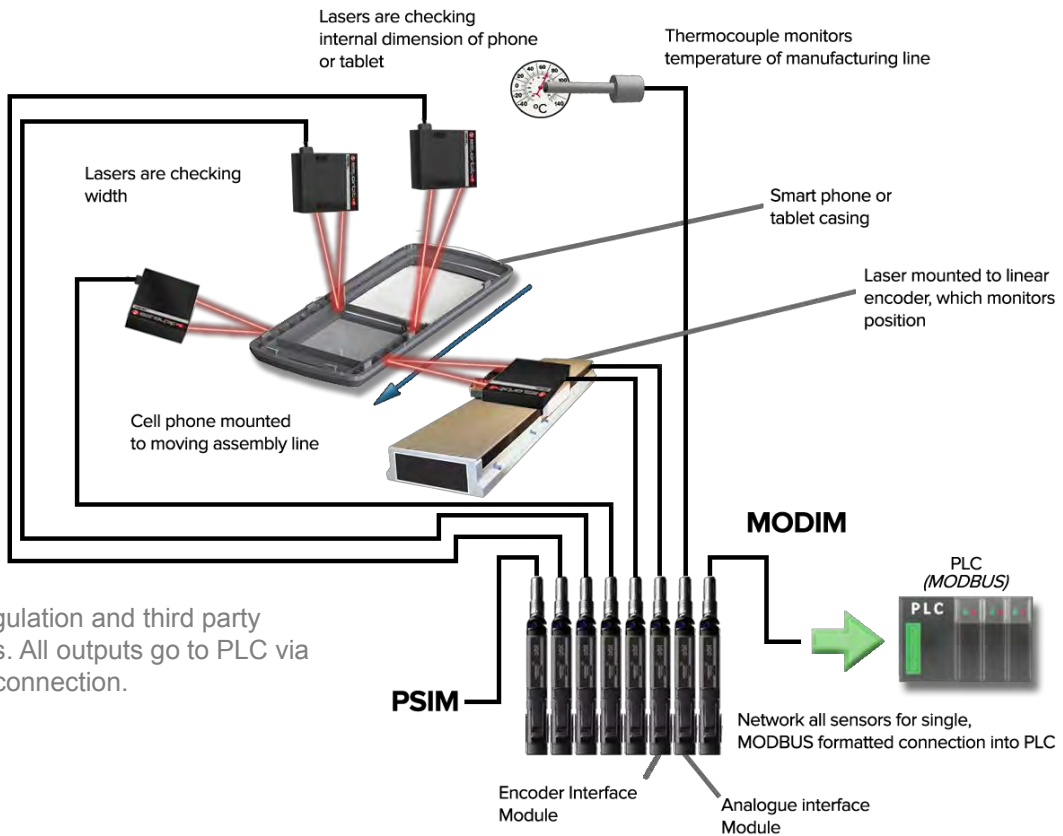





Laser Triangulation and third party Transducers. All outputs go to PLC via one simple connection.



Orbit® 3 Digital Measurement System: Controllers

Provide a wide range of Orbit® 3 controllers which interface to PC's and PLC's

	USBIM	ETHIM	RS232IM	RS485IM	WIM	MODIM
						
Connection	USB 2.0	Ethernet	RS232	RS485	Bluetooth	MODBUS RTU
Data Rate (max) Baud	12MB	10/100 MB	115200B	115200B	3Mbps	115200B
No of Modules	150	150	150	150	150	150
No of Module powered ¹	4	0	0	0	0	0
Measurement Modes ³	All	Static, Readburst	Static, Readburst	Static, Readburst	Static, Readburst	MODBUS
Readings per second ²	3906 (max)	300 (typical)	150 (typical)	150 (typical)	25 (typical)	MODBUS
Nominal Power Requirement mA @ 5V (No load)	250	350	62	62	120	62

Note 1 The USB controller can power up to 4 Orbit® Modules of most types. Some products require additional power supply modules.









Note 2 Readings per second for up to 16 modules.

Note 3 See measurement mode table.



CONNECT TO THIRD PARTY SENSORS

We offer a range of modules to provide interfaces to other transducers and control processes. The flexible AIM (Analogue Input Module) can take inputs from any transducer with a voltage or current output, the EIM (Rotary) Encoder Input Module provides a route to angle information which can facilitate part profiling and the DIOM provides control inputs and outputs.

	AIM	EIM	DIOM	DIM
	 	 	 	 

Input Type	Analogue	Pulse (TTL)	Discrete	DIM
Typical Input	load cells, temperature transducers, airgauge	Rotary Encoder	Switch	Digitmatic Transducer
Input Range ¹	±10V, ±5V, 0-10V, 0-5V 4-20mA, PT100	30V @ 10mA	30V @ 1mA	As pre transducer
Input Frequency	460Hz	1.2MHz	N/A	N/A
Input Channels	1	1	8 ²	1
Output Range	N/A	N/A	Discrete Drive up to 30V @ 50mA	N/A
Measurement Modes ³	All	All	All	Static
Readings per second	3906	3906	3906	Readings on request
Nominal Power Requirement mA @ 5V (No load)	78	49	42	29

Note 1 AIM: Other ranges available on request

Note 2 Each channel can be configured as either input or output

Note 3 See measurement mode table



POWER SUPPLY INTERFACE MODULES (PSIM)

PSIMs are used to power a network of Orbit® modules and sensors from an AC or DC power source. Most sensors and modules run on 5V, except Orbit® LT and Orbit® LTH which also require 24VDC. Certain PSIMs can output both voltages.



Technical Specification

Product		AC PSIM	DC PSIM	DC PSIM/24/5	Aux AC PSIM/24
Primary Output	VDC	5	5	5	24
	Current (A)	1.8	1.8	1.8	1.0
Secondary Output	VDC	None	None	24 (Note 1)	None
	Current (A)	None	None	Note 2	None
Max No of Orbit Modules		31	31	31	(Note 3)
Supply Voltage	VAC	100 to 240	N/A	N/A	100 to 240
	VDC	N/A	10 to 30	10 to 30	N/A
Supply Frequency	Hz	50-60	DC	DC	50-60
Supply Connection (Note 4)		IEC320Plug	2 m Cable	2 m Cable	IEC320Plug

The AC PSIM is supplied connected to a mains power Module with the appropriate mains lead.

The DC PSIM is supplied with a standard 2 m cable.

Environmental

Sealing	IP43 for Module and TCON
Storage Temperature °C	-20 to + 70
Operating Temperature °C	0 to 60
EMC Emissions	EN61000-6-3
EMC Immunity	EN61000-6-2
Weight and Dimensions	Standard Orbit® Module

Note 1: 24V output of DC PSIM will track the DC input.

Note 2: 24V current depends on external supply.

Note 3: the Aux AC PSIM only supplies 24V auxillary power for products that require additional 24V in addition to the standard 5V, these PSIMs do not power the Orbit® Network.

Note 4 : The country specific mains cable is supplied when ordering.



SOFTWARE DRIVERS

Connect Orbit® to SPC, Excel, or build your own program with the Orbit® Support Pack

FEATURES

- Windows 8, 7, and XP 64 bit and 32 bit Compatible
- Managed Code based on Microsoft .NET Framework
- OrbMeasureLite Application – basic system up and going out of the box
- Orbit® Library Tester contains source code for all Orbit® commands which may be used by customers to develop own applications
- Language specific programming examples

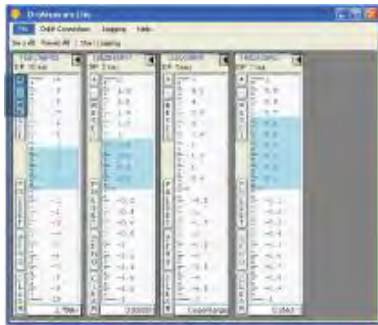

Orbit® Measure Lite Demo

To download the latest support packs for free

MEASUREMENT MODES

Several different Orbit® measurement modes are available with the support pack and interface modules

Measurement Mode	Description	Application
Static	In this mode the Orbit Modules are communicated with on an individual basis. Each module is asked for its measurement data by the controller as required.	Static measurement of attributes
Dynamic	Dynamic mode is a method to obtain synchronised data from transducer/modules on the Orbit network at high speeds up to 3906 readings per second. Data capture can be triggered from an Encoder Input Module or from the Controller Module.	Profiling, High Speed monitoring.
Readburst	ReadBurst command retrieves a single, synchronised block of readings from transducers/modules on the Orbit Network.	High Speed Synchronised readings

orbit3

READOUTS

Connect Orbit® transducers to a variety of stand-alone display units



SI 3500

- Dual input channels (A and B)
- Zero, Preset or Absolute
- Selectable metrology functions e.g. A+B, (A+B)/2
- Discrete Input and Outputs
- Serial Interface Port
- Data logging
- Analogue Outputs

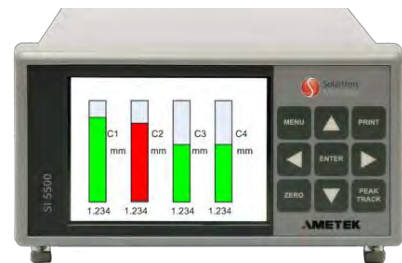

SI 5500

- Up to 31 input channels; up to 16 displayed
- Zero, Preset or Absolute
- User programmable metrology functions with full maths capability
- Discrete Inputs and Outputs
- Serial Interface Port
- Data logging

orbitACS

Orbit® ACS is a specific range of products which integrate contact and non contact linear measurement transducers with an electronics module that includes an integral display. These products are excellent for a small number of measuring points, are stand alone (i.e. do not require PSIMS or Orbit® Controllers) and have an integral Modbus and ASCII interface plus flexible discrete I/O

See separate Orbit® ACS datasheet for more details



SI 100

- Single channel



SI 200

- Dual channel



SI 400

- Four channel

PIE (Probe Interface Electronics)

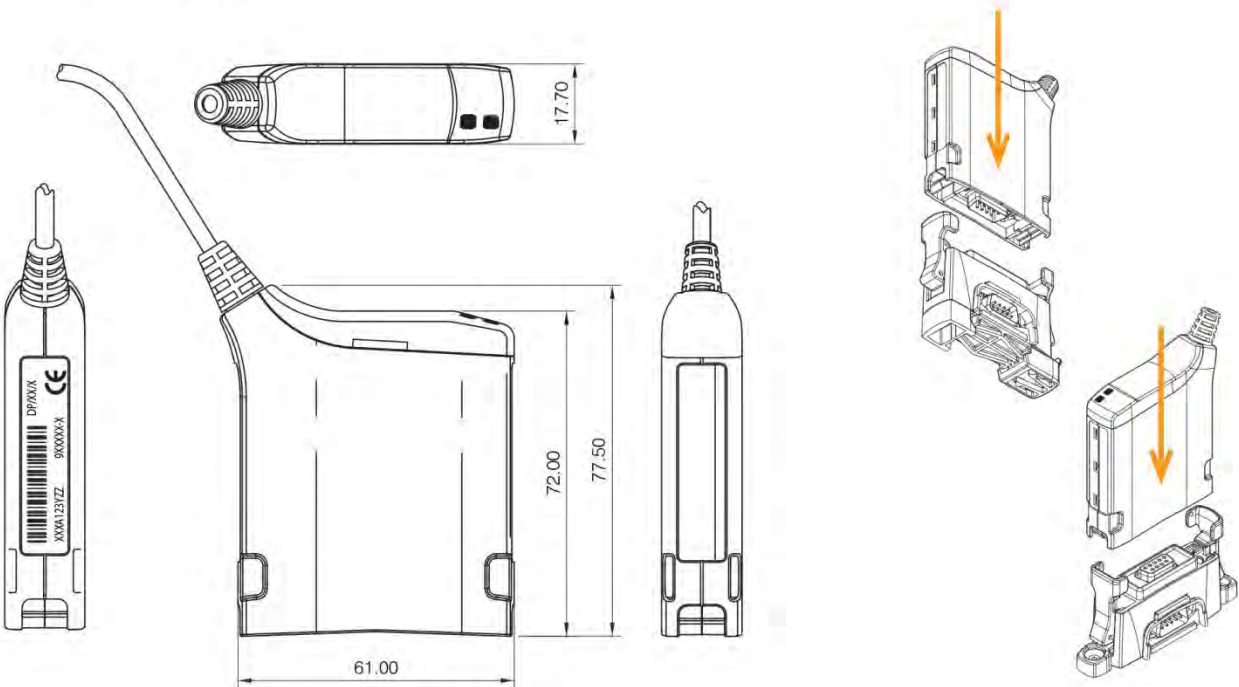

T-CON Orbit network connector

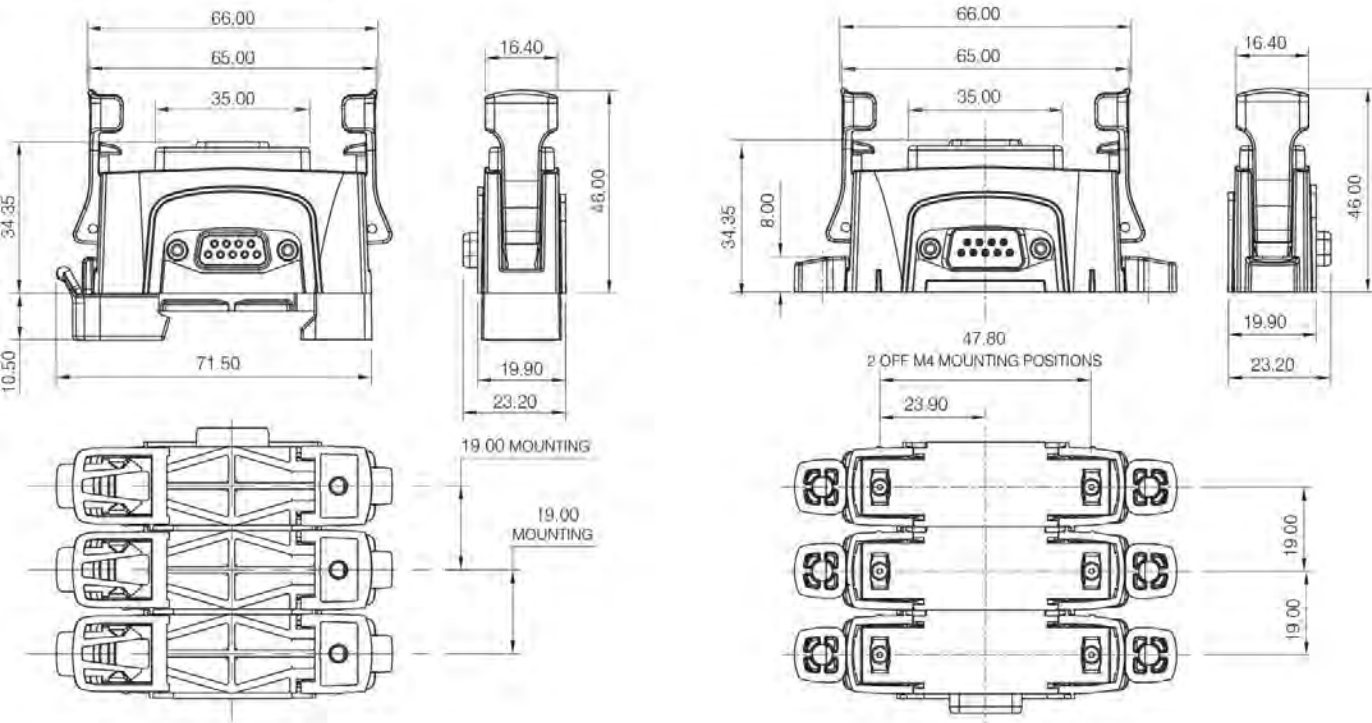

VIEW SHOWING 3 ASSEMBLIES PLUGGED TOGETHER

VIEW SHOWING 3 ASSEMBLIES PLUGGED TOGETHER

T-CON with 32 mm DIN raise connector

T-CON with mounting feet option

PSIM (Power Supply Interface Module)

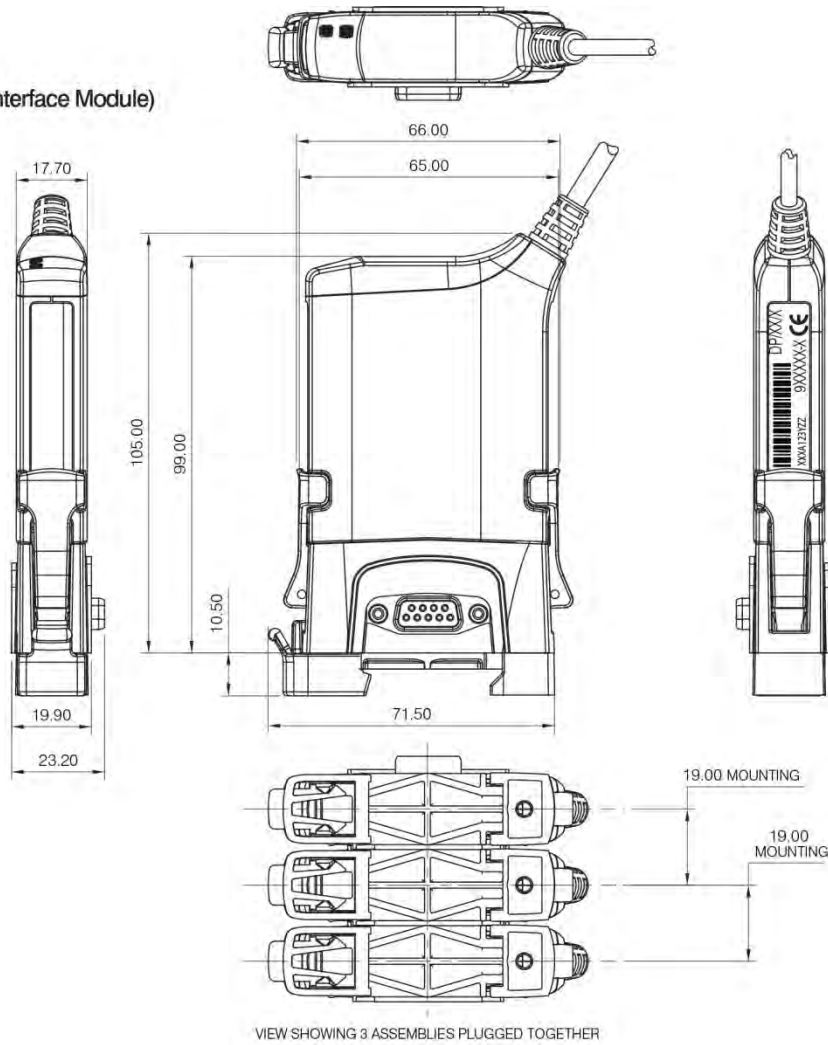

PSIM transformer

